

SEPTIC SEWAGE PUMPS

A Division of Southwestern Controls



DBM40-175

6.2 psi max. pressure (.43 bar) 56 LPM open flow (60 Hz)

DBM60-175

6.3 psi max. pressure (.44 bar) 96 LPM open flow (60 Hz)

DBM80-175

7.2 psi max. pressure (.50 bar) 118 LPM open flow (60 Hz)

Product Dimensions (inches, mm)

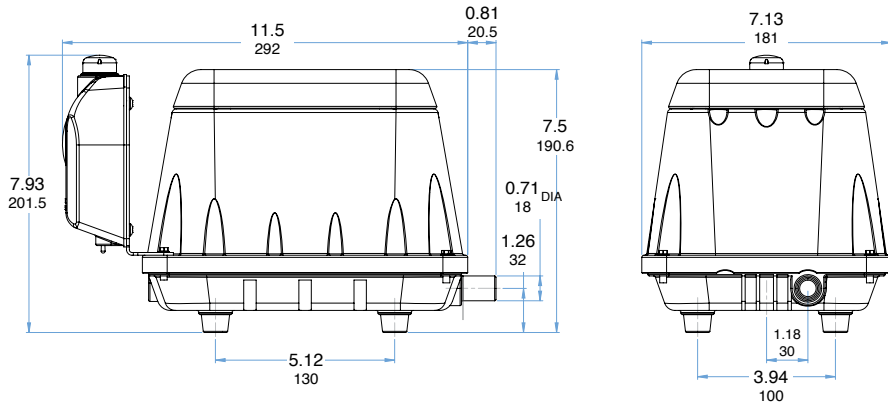

Product Specifications

| Model Number | Operating Voltage Frequency (Hz) | Typical Operating Power (W) | Typical Operating Pressure (psi/bar) | Sound Level dB(a) | Net Wt. | |
|--------------|----------------------------------|-----------------------------|--------------------------------------|-------------------|---------|-----|
| | | | | | lb | kg |
| DBM40-AL2 | 120-60 | 45 | 1.85 / 0.13 | 46 | 14.7 | 6.7 |
| DBM60-AL2 | 120-60 | 63 | 2.13 / 0.15 | 47 | 16.7 | 7.6 |
| DBM80-AL2 | 120-60 | 84 | 2.13 / 0.15 | 51 | 16.8 | 7.6 |

- All models include pigtail style electrical leads
- Low noise and vibration
- **UL** listed to **UL** 1450 air compressor/vacuum pump and Canadian Standard C22.2 No 68-92
- **CE** In compliance with the European Community's Machinery Directive
- All models include low pressure alarm
- Alarm system includes buzzer and warning light
- Alarms include On, Mute, and Test Mode switches
- Low pressure < 1 psi

Product Performance

